



## **Basic Router Pod Planning and Installation Guide**

**For Cisco Networking Academy® CCNA 3.x Curriculum**

**Document Version: 2005-09-03**

**Copyright © 2005, Network Development Group, Inc.  
[www.netdevgroup.com](http://www.netdevgroup.com)**

NETLAB Academy Edition and NETLAB+ are registered trademarks of Network Development Group, Inc.

Cisco, IOS, Cisco IOS, Networking Academy, CCNA, CCNP, and PIX are registered trademarks of Cisco Systems, Inc.

1	Introduction.....	3
1.1	Lab Orientation.....	4
1.2	Deviations.....	4
2	Lab Device Requirements.....	4
3	Control Device Requirements.....	6
3.1	Control Switch Overview.....	6
3.2	Access Server.....	7
3.3	Switched Outlets.....	7
4	Pre-requisites.....	7
4.1	Setup Control Devices.....	7
4.2	Upload IOS Images.....	8
4.3	Disable User Logins (optional).....	8
5	Adding the Pod.....	9
5.1	Start the New Pod Wizard.....	9
5.2	Add a Basic Router Pod.....	9
5.3	Select Control Switch and Ports.....	9
5.4	Select Access Server(s) and Ports.....	10
5.5	Select Switched Outlets.....	11
5.6	Select Router Types.....	12
5.7	Select Software Images and Recovery Options.....	13
5.8	Select a Pod ID.....	14
5.9	Select a Pod Name.....	14
6	Cable the Pod.....	16
7	Testing the Pod.....	17
8	Finishing Up.....	18
8.1	Bring the Pod(s) Back Online.....	18
8.2	Enable Basic Router Pod and CCNA 3.x Exercises.....	19
8.3	Schedule a Lab Reservation for Your New Pod.....	21

## PART 1 – PLANNING

### 1 Introduction

NETLAB Academy Edition® features three pods for use with the CCNA 3.x curriculum, Basic Router Pod, Basic Switch Pod, and Advanced Router Pod. This guide documents the NETLAB<sub>AE</sub> Basic Router Pod, used with *CCNA 3.x Basic Router Configuration Labs*.

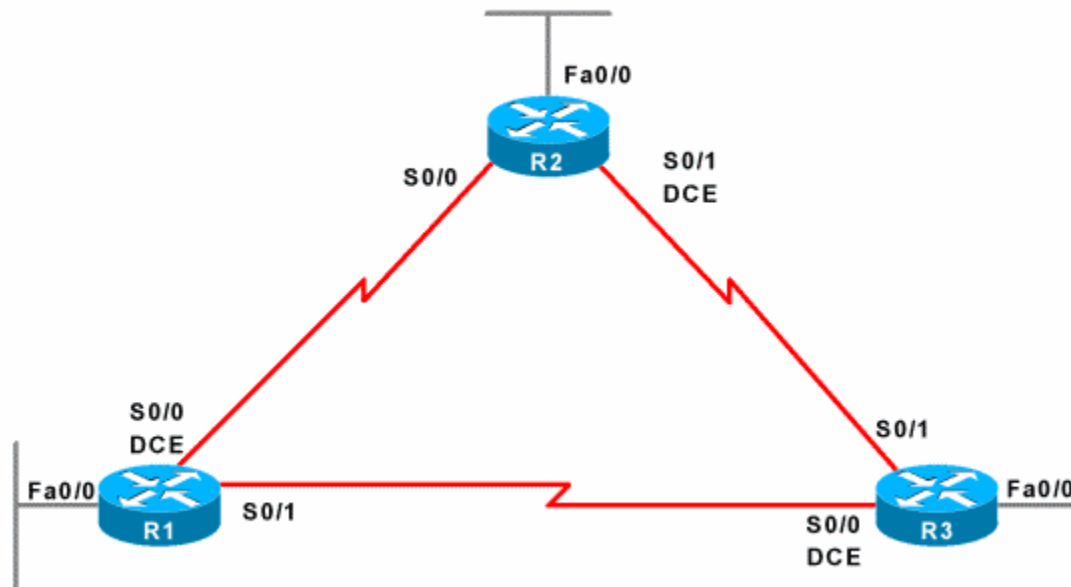

You may have up to eight Basic Router Pods per NETLAB<sub>AE</sub> system.

The NETLAB<sub>AE</sub> Basic Router Pod features direct access to the console of routers R1, R2, and R3.

## 1.1 Lab Orientation

This document assumes that you are familiar with the CCNA 3.x curriculum and labs.

## 1.2 Deviations

Users often contact our technical support team for lab-related problems. Users are typically not aware that there are many NETLAB<sub>AE</sub> servers and may be easily confused by local deviations from the standard curriculum and labs.

If your NETLAB<sub>AE</sub> pods will be made accessible outside your local Academy, please be conservative in your deviations and substitutions.

Even if your user community is local or relatively small, we recommend that you (1) document the specifics of your pods and (2) use the NETLAB<sub>AE</sub> *News and Announcements* feature to point users to your documentation.

## 2 Lab Device Requirements

Lab devices are part of the topology and users can interact with them either directly through the console or indirectly via Telnet and other protocols.



The Basic Router Pod includes three routers, R1, R2 and R3.

The following table depicts the interface requirements for each router:

Router	Ethernet Interfaces Required	Serial Interfaces Required
R1	1	2
R2	1	2
R3	1	2

The Ethernet interface must be a built-in interface, which is capable of activation from the ROM monitor mode. All NETLAB<sub>AE</sub> supported routers have at least one Ethernet interface that meets this requirement.

The serial interfaces may be built-in, or provided by modular interface cards such as the WIC-2AS or WIC-2T. Serial connections between routers require the appropriate serial cables. You can use DTE and DCE cables back-to-back, or special cables that provide both DTE and DCE in one cable (available from SIGMAnet).

NETLAB Academy Edition® has an interface name translation feature that allows configuration files to be loaded without errors on different router platforms. As a

configuration is being loaded, NETLAB<sub>AE</sub> will substitute the correct interface names if necessary. To do this, NETLAB<sub>AE</sub> maintains a fixed table of interface names that should present on each router model. This may influence the selection of modular interface cards and slot placement within the router. The NETLAB<sub>AE</sub> hardware support web pages depict the expected interface names for each router model.

NETLAB<sub>AE</sub> has been designed to support a broad range of hardware to allow great flexibility with equipment selection

Keep in mind that the hardware you select must meet both these requirements:

1. Supported by NETLAB<sub>AE</sub>.
2. Meet the specifications for the lab exercises of the curriculums your Academy wishes to implement.

**Please Note: Due to the dynamic nature of curriculum requirements, NDG makes no guarantee that every NETLAB<sub>AE</sub> supported device will meet all curriculum or lab requirements.**

We strongly recommend that a knowledgeable person carefully study the curriculum and labs taught by your Academy before deploying a NETLAB<sub>AE</sub> lab bundle (pod) or specific Cisco equipment model. NDG makes no guarantee that every NETLAB<sub>AE</sub> supported device will meet all curriculum or lab requirements.

To aid in this study we recommend using the following resources:

- Review the information provided on the NETLAB<sub>AE</sub> website for information on NETLAB<sub>AE</sub> supported equipment and IOS images. Not all NETLAB<sub>AE</sub> supported equipment is an ideal choice for some of the Cisco Networking Academy curriculum modules or labs.  
<http://www.netdevgroup.com/ae/labdevices.htm>
- Consult your Cisco Networking Academy Program contact.
- Consult your Cisco sales representative.

### 3 Control Device Requirements

NETLAB<sub>AE</sub> *control devices* provide internal connectivity, console access, and managed power. Control devices are dynamically managed by NETLAB<sub>AE</sub> and are not accessible or configurable by end users.

⇒ Management of control devices is covered in the *NETLAB+ Administrator Guide*.

The Basic Router Pod requires the following control device resources:

Control Device Resource	Quantity Required
Control Switch	3 Consecutive ports
Access Server	3 lines
Switched Outlet Devices	3 outlets

#### 3.1 Control Switch Overview



NETLAB<sub>AE</sub> uses a control switch to provide connectivity between devices in the Basic Router Pod.

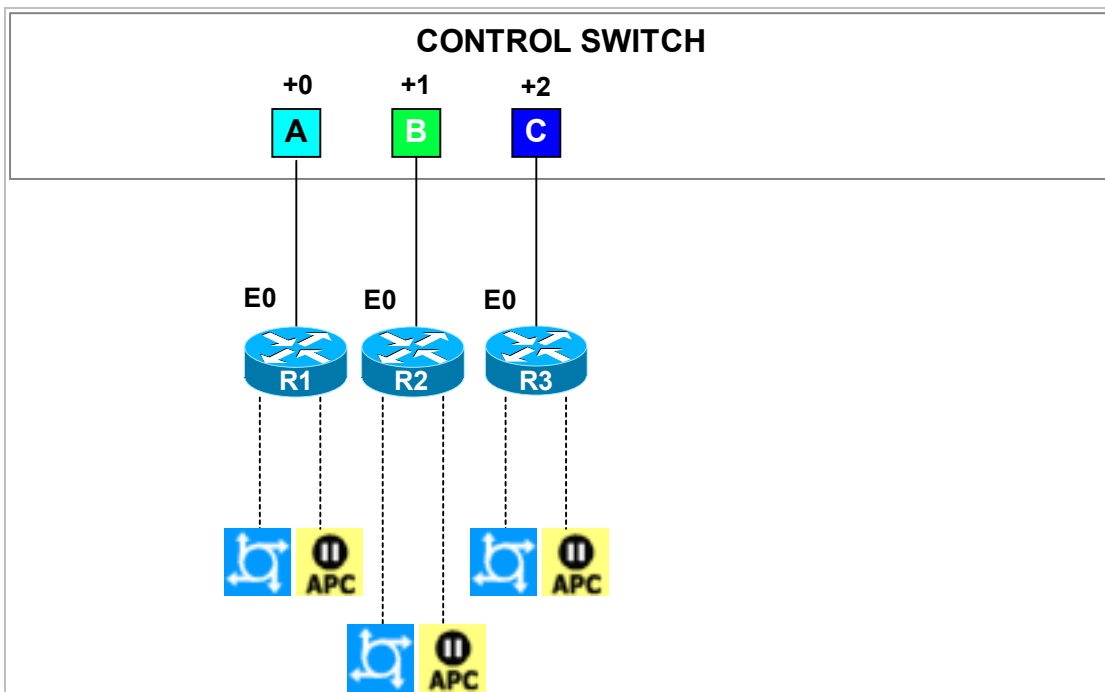

The Basic Router Pod requires 3 consecutive ports on a control switch.

Ports are labeled +0 to +2 in the diagram and are relative to the *base port* of your choice. As with all pods, you choose a base port for the Basic Router Pod. To determine the actual port numbers, simply add the base port number chosen for this pod to the depicted relative port numbers. For example, if the base port is 5, the actual port numbers will be 5 to 7.

Using SNMP, NETLAB<sub>AE</sub> will automatically assign and program VLANs on ports +0 to +2. These VLANs are depicted as letters A, B, and C. Each NETLAB<sub>AE</sub> pod has a unique *VLAN pool* and the actual VLAN numbers will be unique for each NETLAB<sub>AE</sub> pod. This is to avoid conflict between pods.

### 3.2 Access Server



Access servers provide console connections to lab routers, lab switches, and lab firewall devices so that users can access these devices from NETLAB<sub>AE</sub>. The Basic Router Pod requires three access server ports. These ports provide console access to R1, R2 and R3.

### 3.3 Switched Outlets



Switched outlets provide managed electrical power, allowing NETLAB<sub>AE</sub> and users to turn lab equipment on and off. The Basic Router Pod requires a switched outlet for R1, R2, and R3.

## PART 2 - IMPLEMENTATION

### 4 Pre-requisites

This section covers tasks that should be executed prior to adding a Basic Router Pod.

#### 4.1 Setup Control Devices



Using the guidelines in section 3, decide which control switch ports, access server ports, and switched outlets you will use for your Basic Router Pod. Add control devices if necessary. Control device configuration is documented in the *NETLAB+ Administrator Guide*.

## 4.2 Upload IOS Images



Upload the IOS images for R1, R2 and R3. NETLAB<sub>AE</sub> will recover these images on the appliance if they are erased from flash.

## 4.3 Disable User Logins (optional)



You must take all equipment pods offline to add pods or configure control devices. You may wish to disable user logins during this time.



## 5 Adding the Pod

This section walks you through the process of adding a Basic Router Pod using the NETLAB<sub>AE</sub> New Pod Wizard.

### 5.1 Start the New Pod Wizard



Login to the administrator account.

Select Equipment Pods.

Select  Take All OFFLINE if any of the pods are online. Caution: this will cancel any reservations in progress.

Select  Add a Pod.

The New Pod Wizard will now help you add an equipment pod to your system.

### 5.2 Add a Basic Router Pod

#### BASIC ROUTER POD





When prompted, select Basic Router Pod.



3 Routers

### 5.3 Select Control Switch and Ports

A Basic Router Pod requires 3 consecutive control switch ports. NETLAB<sub>AE</sub> will present a list of the control switches on your system. Switches that meet the port requirement can be selected. Choose one control switch for your new pod.

CONTROL SWITCHES				
SELECT	ID	SWITCH TYPE	PORTS THAT ARE FREE	COMMENT
	1	Catalyst 2950-24	PORT 4-12	OK TO USE
INELIGIBLE	2	Catalyst 2950-24	PORT 15-16	NOT ENOUGH CONSECUTIVE PORTS
	3	Catalyst 3550-24	PORT 11-16	OK TO USE
INELIGIBLE	4	Catalyst 3550-24	PORT 15-16	NOT ENOUGH CONSECUTIVE PORTS
	5	Catalyst 1924 Enterprise Edition	PORT 1-16	OK TO USE
	6	Catalyst 2950-24	PORT 1-16	OK TO USE

Next, select the ports you want to use.

A Basic Router Pod v1 requires 3 consecutive control switch ports.

Which free 3-port range would you like to use?

Ports 4 to 6

Ports 4 to 6

Ports 5 to 7

Ports 6 to 8

Ports 7 to 9

Ports 8 to 10

Ports 9 to 11

Ports 10 to 12

Next Back Cancel

#### 5.4 Select Access Server(s) and Ports

A Basic Router Pod requires 3 access server ports.

It is a good idea to use consecutive ports on one access server if possible. This practice will make it easier to cable and troubleshoot. If consecutive ports are not available, you can use non-consecutive ports, on different access servers if necessary.

When specifying ports, use the port numbers shown on the access server itself. Some models start at port 1 (Cisco 2509 and 2511) and others start at port 0 (Cisco NM-16A and NM-32A modules).

NETLAB<sub>AE</sub> allows you to choose consecutive ports on one access server, or you can choose “Let me pick” to select an access server and port for each device.

ACCESS SERVERS		
ID	TYPE	PORTS THAT ARE FREE
1	Cisco 2511-RJ	4-11, 14-16
2	Cisco 2511-RJ	3-16
3	NM-32A Module in Cisco Router	1, 3-31
4	NM-32A Module in Cisco Router	0-31

A Basic Router Pod v1 requires 3 access server ports.

Use 3 consecutive ports on access server 1 starting at port 0

Let me pick the access server and ports for each device

Next Back Cancel

“Let me pick”, allows you to make granular selections.

SELECT AN ACCESS SERVER AND PORT FOR EACH LAB DEVICE		
LAB DEVICE	ACCESS SERVER (ID)	PORT
R1	2	13
R2	3	14
R3	1	7

## 5.5 Select Switched Outlets

A Basic Router Pod requires 3 switched outlets.

It is a good idea to use consecutive outlets on one switched outlet device (SOD) if possible. This practice will make it easier to cable and troubleshoot. If consecutive outlets are not available, you may use non-consecutive outlets, spanning multiple SODs if necessary.

SWITCHED OUTLET DEVICES (SOD)		
ID	TYPE	OUTLETS THAT ARE FREE
1	APC 9211 MasterSwitch	4-8
2	APC 9211 MasterSwitch	1, 3-8
3	APC 9211 MasterSwitch	6-8
4	APC 7900 Switched Rack PDU 1-8	

A Basic Router Pod v1 requires **3** switched outlets.

Use 3 consecutive outlets on switched outlet device  starting at outlet

Let me pick select outlets for each device manually

“Let me Pick”, will allow you to make granular selections.

SELECT A SWITCHED OUTLET FOR EACH LAB DEVICE		
LAB DEVICE	SOD	OUTLET
R1	4	5
R2	4	7
R3	3	8



## 5.6 Select Router Types

Please specify a model for R1, R2 and R3.

⇒ Your selections are used to assign the appropriate NETLAB<sub>AE</sub> device driver.



⇒ Improper selections may cause errors.

⇒ NETLAB<sub>AE</sub> may offer selections that meet the port requirements, but do not support the curriculum. See section 2.

SELECT A MODEL FOR EACH LAB DEVICE		
LAB DEVICE	TYPE	MODEL
R1	 Router	Cisco 2501
R2	 Router	Cisco 2501
R3	 Router	Cisco 2501

## 5.7 Select Software Images and Recovery Options

NETLAB<sub>AE</sub> scrubs R1, R2 and R3 at the end of lab reservation or upon request. During a scrub, NETLAB<sub>AE</sub> can recover an IOS image if it has been erased from flash.

SELECT AN IMAGE AND RECOVERY OPTIONS FOR EACH LAB DEVICE			
DEVICE	TYPE	SOFTWARE IMAGE	RECOVER USING SPECIFIED IMAGE
R1	 Cisco 2501	c2500-c-l.121-5.T9.bin ▼	if specified image not in flash ▼
R2	 Cisco 2501	c2500-c-l.121-5.T9.bin ▼	if specified image not in flash ▼
R3	 Cisco 2501	c2500-c-l.121-5.T9.bin ▼	if specified image not in flash ▼

You have three choices for flash recovery:

Recovery Using Specified Image	During A Scrub Operation...
If specified image not in flash	Restores the selected software image if that image is not in flash.
If no image in flash (erased)	Restores the selected software image if there are no .bin images in flash. No action is taken if flash contains a .bin image (even if it is not the specified one).
Never (device may become unusable)	NETLAB <sub>AE</sub> will take no action if the flash does not contain a bootable image. In this case, NETLAB <sub>AE</sub> automated boot process will fail and manual restoration of IOS will be required.

⇒ If you select an automatic recovery option, you must also select a software image supported by the curriculum (see 2).

## 5.8 Select a Pod ID

Each pod is assigned a unique numeric ID.

Each equipment pod is assigned a unique numeric ID.

Please select a Pod ID.

Pod ID:

## 5.9 Select a Pod Name

Each pod can have a unique name. This name will appear in the scheduler, along with the pod type.

Each equipment pod is assigned a unique name.

Pod Name:

## 5.10 Verify Your Settings

At this point NETLAB<sub>AE</sub> has added the pod to its database. However, the pod has not been brought online yet. You will want to cable up the pod and run a pod test before bringing the pod online. These tasks are discussed in the remaining sections.

**New Pod Wizard** NETLAB

 The New Pod Wizard has added the pod.









- ◆ New pods are not brought online automatically.
- ◆ You should cable the pod and run a pod test before bringing the pod online.

After you click OK, the new pod will appear in the list of equipment pods.

Click on the magnifier button or pod ID to manage you new pod.

	<b>3</b>	 <b>BASIC ROUTER POD</b> 3 Routers	Jupiter	 OFFLINE	IDLE
---	----------	--	---------	---	------

NETLAB<sub>AE</sub> will display the status of the pod and the high-level settings for each device, PC, and control switch.

POD 3 - ROUTERS, SWITCHES, AND FIREWALLS (click on the GO buttons to reconfigure devices)					
GO	NAME	TYPE	 ACCESS PORTS	 SWITCHED OUTLETS	SOFTWARE IMAGE
	 R1	Cisco 2501	AS 2 PORT 13	SOD 4 OUTLET 5	c2500-c-l.121-5.T9.bin
	 R2	Cisco 2501	AS 3 PORT 14	SOD 4 OUTLET 7	c2500-c-l.121-5.T9.bin
	 R3	Cisco 2501	AS 1 PORT 7	SOD 3 OUTLET 8	c2500-c-l.121-5.T9.bin
POD 3 - CONTROL SWITCH					
SWITCH ID	POD PORT RANGE	BASE VLAN	VLAN POOL		
 1	4-6	120	120-122		

## 6 Cable the Pod

Use the NETLAB<sub>AE</sub> cable chart feature to help you connect the lab devices in your pod. The chart is generated in real-time and contains port-specific information based on your current lab device and control device settings.

The cable chart function is accessed from the pod management page.





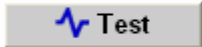

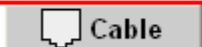

**Pod 3 -- Management Options**

 **Online** Bring this pod ONLINE and make it available for reservations.

 **Test** Tell me if this pod is working properly.

 **Cable** Show me how to cable this pod.

 **Delete** Remove this pod from NETLAB.

CABLE CHART FOR POD 3			
 <b>R1 (Cisco 2501)</b>			
CONNECT FROM	USING CABLE	CONNECT TO	
Ethernet0	Ethernet CAT-5 Straight Through	 C/S 1	Port 4
Console	Console Cable	 A/S 2	Port 13
Power	Power Cord	 SOD 4 	Outlet 5
Serial0 DCE	Back-to-back serial cables	 R2	Serial0 DTE
Serial1 DTE	Back-to-back serial cables	 R3	Serial1 DCE
 <b>R2 (Cisco 2501)</b>			
CONNECT FROM	USING CABLE	CONNECT TO	
Ethernet0	Ethernet CAT-5 Straight Through	 C/S 1	Port 5





## 7 Testing the Pod

After all routers have been installed, you should run a pod test to verify that your pod is working. The pod test will detect common configuration and cabling problems.

**Pod 3 -- Management Options**

 **Online** Bring this pod ONLINE and make it available for reservations.









 **Test** Tell me if this pod is working properly.

 **Cable** Show me how to cable this pod.

 **Delete** Remove this pod from NETLAB.

⇒ Some tests may take a long time. During the BOOTIOS test, NETLAB<sub>AE</sub> may have to load the specified IOS image if it is not in flash. Some images are very large and can take up to 30 minutes to program into flash memory.

If you cannot resolve an issue and decide to contact technical support, please cut and paste the text from the POD TEST LOG and include with your e-mail.

TESTING POD 3				
DEVICE	TYPE	TEST	STATUS	DETAILS
 Control Switch 1	Catalyst 2950-24		 PASSED	3 test(s) passed, device looks good
 R1	Cisco 2501	CONSOLE	 RUNNING	recover console test
 R2	Cisco 2501	CONSOLE	 RUNNING	recover console test
 R3	Cisco 2501	CONSOLE	 RUNNING	recover console test

**POD TEST LOG**

[00:02] CS1: Applying pod VLAN map on control switch 1 - PASS  
 [00:02] CS1: Setting up VLAN pool on control switch 1 - PASS  
 [00:02] CS1: Pinging control switch at 169.254.1.11 - PASS  
 TESTING POD 3, Basic Router Pod, (3 routers)...

**TESTING IN PROGRESS**

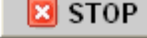
 **STOP**

## 8 Finishing Up

### 8.1 Bring the Pod(s) Back Online

Now you can bring the pod online and make it available for lab reservations. You can bring just this pod online by clicking the  Online button under Management Options.

**Pod 3 -- Management Options**















 **Online** Bring this pod ONLINE and make it available for reservations.

 **Test** Tell me if this pod is working properly.

 **Cable** Show me how to cable this pod.

 **Delete** Remove this pod from NETLAB.

Alternatively, you can click  Bring All ONLINE on the Equipment Pods page. Choose this option when you have no more additions or modifications to pods or control devices and you wish to put all pods into service.

EXISTING PODS (click on the GO buttons to manage a pod)					
GO	ID	POD TYPE	POD NAME	STATUS	ACTIVITY
	<a href="#">1</a>	 3 Routers	POD 1	 OFFLINE	IDLE
	<a href="#">2</a>	 2 PIX Firewalls PCs & Servers	Zeusmax	 OFFLINE	IDLE
	<a href="#">3</a>	 3 Routers	Jupiter	 OFFLINE	IDLE
	<a href="#">5</a>	 2 Firewall Routers PCs & Servers	Galactica	 OFFLINE	IDLE
	<a href="#">6</a>	 2 PIX Firewalls PCs & Servers	Pegasus	 OFFLINE	IDLE

## 8.2 Enable Basic Router Pod and CCNA 3.x Exercises

To make the Basic Router Pod and CCNA 3.x lab exercises available to classes and students, you must first enable CCNA 3.x in a new or existing class.

To add or edit class information, log into NETLAB<sub>AE</sub> using your instructor account. See the Instructor Accounts section of the *NETLAB+ Administrator Guide* for details.

**LOGIN**

**Username:**

**Password:**

Select **Class** from the menu bar at the top of the MyNETLAB page, or the link in the body of the page.



The Class Manager page will be displayed.

 Select to add a new class or select an existing class from the class list by clicking on a class name.

CISCO NETWORKING ACADEMY PROGRAM - MY ACADEMY					
CLASS NAME	INSTRUCTOR	STUDENTS	TYPE	START DATE	END DATE
<a href="#">▶ 2005 Semester 2</a>	Jane Doe	2	CNAP	Mar 8, 2005	Mar 8, 2006
<a href="#">▶ Antonio's FNS Class</a>	Antonio Labmeister	2	CNAP	Feb 17, 2005	Feb 17, 2006

⇒ You may now enable more than one set of content. Previous NETLAB<sub>AE</sub> versions only allowed one content selection.

**Edit Class** INSTRUCTOR  
**MyNETLAB** [Logout](#) [Help](#) **janedoe**

- Edit the information for this class, then click OK.
- For help with the form, click Help on the menu bar.

**Class Name**  **REQ**

**Primary Instructor**

**Content and Exercises**  
Labs available to students

- CCNA 2.1
- CCNA 3.0
- CCNA 3.0 Skills Assessment
- CCNP 3.0
- FNS/PIX
- FNS/Router

**Starting Date**

**Ending Date**

### 8.3 Schedule a Lab Reservation for Your New Pod.

To schedule a lab reservation, select **Scheduler** from the menu bar or the link on the body of the MyNETLAB page.



The Scheduler Options screen will be displayed. Detailed descriptions of the scheduler options are available by selecting **Help** on the menu bar. In this example, we will reserve an equipment pod for your own use.

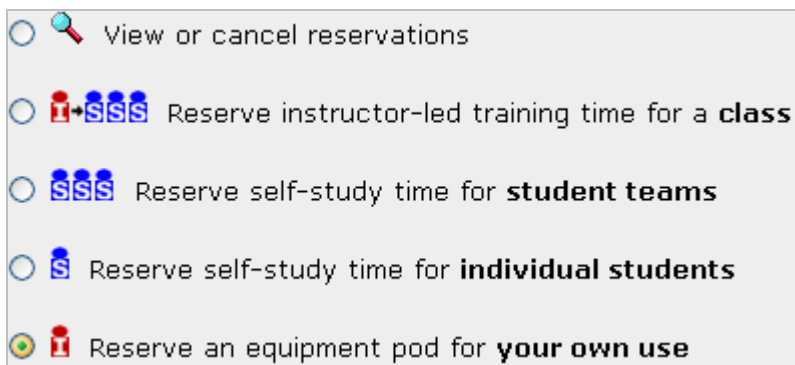

Select **OK** to proceed to the reservation calendar.

**Please Note: The selection of pods depicted may be different from the pods available at your site.**

**Reservation Calendar** INSTRUCTOR **janedoe**

MyNETLAB Logout

March 2005						
Sun	Mon	Tue	Wed	Thu	Fri	Sat
		1	2	3	4	5
6	7	8	9	10	11	12
13	14	15	16	17	18	19
20	21	22	23	24	25	26
27	28	29	30	31		

**Wednesday**  
**March**  
**9**  
**2005**

Today's Date and Local Time  
[Mar 9, 2005 11:27 AM](#)  
Mountain Time (US & Canada)

Select a pod and reservation time by clicking on a

	<b>Jupiter</b> <b>BASIC ROUTER POD</b> 3 Routers	<b>Galactica</b> <b>SECURITY ROUTER POD</b> 2 Firewall Routers PCs & Servers	<b>Pegasus</b> <b>SECURITY PIX POD</b> 2 PIX Firewalls PCs & Servers
12am			
1 am			

The reservation time area may be scrolled up and down. Scroll to the bottom to display the color legend.

10pm			
11pm			

	<b>Jupiter</b> <b>BASIC ROUTER POD</b> 3 Routers	<b>Galactica</b> <b>SECURITY ROUTER POD</b> 2 Firewall Routers PCs & Servers	<b>Pegasus</b> <b>SECURITY PIX POD</b> 2 PIX Firewalls PCs & Servers

Color Legend	
	Date you are viewing
	Today's date
	Time reserved for you
	Time reserved for someone else
	Unreserved time
	* Access restricted to specific instructors and classes
	Available time, click to reserve

Select an available time, and the Reserve Instructor Access Time page will be displayed.

<b>Reservation Type</b>	Instructor Access
<b>Equipment Pod</b>	Jupiter
<b>Reserved For</b>	Jane Doe (janedoe)
<b>Start Time</b>	Wed Mar 9, 2005 8:00PM (GMT-07:00) Mountain Time (US & Canada)
<b>End Time</b>	<input type="text" value="Mar"/> <input type="text" value="9"/> <input type="text" value="2005"/> <input type="text" value="9"/> <input type="text" value="30"/> <input type="text" value="PM"/>
<b>Initial Configuration</b>	<input checked="" type="radio"/> restore configs from last Basic Router Pod reservation (if any) <input type="radio"/> no configs loaded (clean)
<input type="button" value="Confirm Reservation"/> <input type="button" value="Back to Calendar"/> <input type="button" value="Cancel"/>	

Review the details of the reservation and select **Confirm Reservation**. You can return to the reservation calendar to see your lab reservation on the time reservation portion. Remember, you may need to scroll the page to see your information.

8pm	 633 janedoe	<input type="button" value="⊕"/>	<input type="button" value="⊕"/>
		<input type="button" value="⊕"/>	<input type="button" value="⊕"/>
9pm		<input type="button" value="⊕"/>	<input type="button" value="⊕"/>
	<input type="button" value="⊕"/>	<input type="button" value="⊕"/>	<input type="button" value="⊕"/>

For more information on scheduling reservations, see the Scheduler section of the *NETLAB+ Instructor Guide*.